

VALLEY FRAMING & BRACING DETAIL

Lumber Size and Grade Minimum Requirements

- Ridge board... 2x6 (min) #2 Southern Pine or better,
- Rafter spans 20'-0" or less... (A)2x4 SP #2, SPF #1/#2, DF #2 or better
(B)2x6 SP #2, SPF #1/#2, DF #2 or better
- Purlins / Lateral bracing... 2x4 SPF #2, HF #2, DF #2 or better
- Sleepers... 2x(width of rafter seat cut) SPF #3 or better
- Cripples and blocking... 2 parallel 2x4 SPF #3
- Truss Below... 2x4 SPF #3 or better
- Truss Below... See design - Southern Pine material

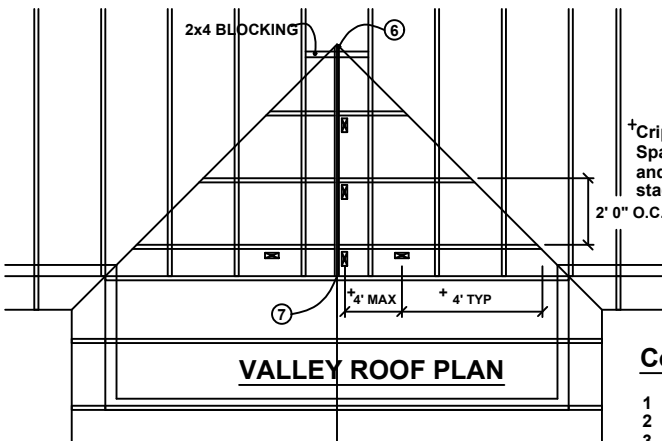

- ===== TRUSS
- ===== TRUSS UNDER VALLEY FRAMING
- ===== VALLEY RAFTER OR RIDGE
- ⊠ CRIPPLE

†Cripples 4'-0" o.c. for 20 psf (TL) and 10 psf (TD) MAX.
Space the cripples for each row starting from the valleys or sleepers and working inward to the ridge board so that cripple locations are staggered between rows.

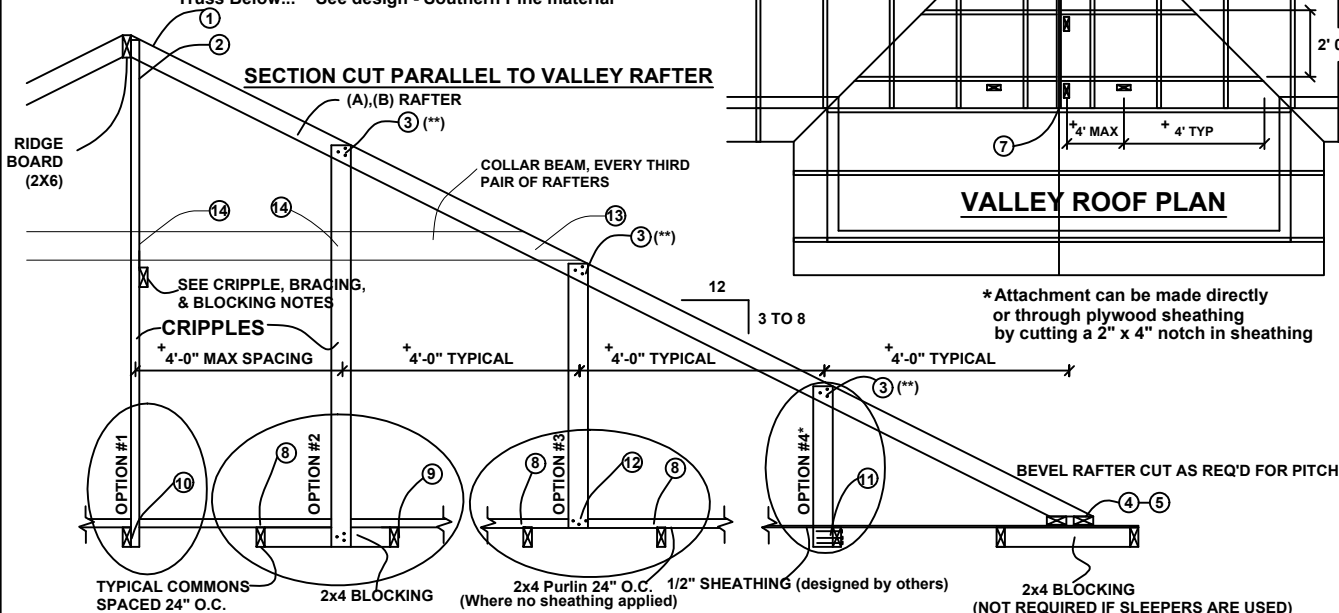

Connection Requirement Notes

- | | | |
|----|--|---------------------------------------|
| 1 | 2x4 rafters to ridge | 3 16d toe-nails |
| 2 | Cripple to ridge | 3 16d face nails |
| 3 | Cripple to rafter | 3 16d face nails |
| | | (**)6 16d face-nails |
| 4 | Rafter to sleeper or blocking | 5 16d toe-nails |
| | Rafter to two 2x4 sleepers | 3 16d toe-nails each sleeper |
| 5 | Sleeper to truss | 3 16d face nails each truss |
| | Two 2x4 sleepers to truss | 2 16d face nails each sleeper & truss |
| 6 | Ridge board to roof block | 3 16d toe-nails |
| 7 | Ridge board to truss | 3 16d toe-nails |
| 8 | Purlin to truss (Typ) | 3 16d nails |
| | Purlin to truss (if cripple is attached to purlin) | 3 16d nails |
| 9 | Truss to blocking | 3 16d end nails |
| 10 | Truss to cripple | 3 16d face nails |
| 11 | Truss to cripple | 3 16d face nails |
| 12 | Cripple to purlin | 3 16d face nails |
| 13 | Collar Beam to Rafter | 3 16d face nails |
| 14 | Collar Beam to Cripple | 3 16d face nails |

Note: 16d (0.162"x3.5") Common Nails

GENERAL NOTES

- Purlins required 2'-0" O.C. in absence of plywood sheathing.
- Trusses without sheathing applied must be evaluated accordingly.
- Purlins should overlap sheathing one truss spacing minimum.
- In cases that this is impractical, overlap sheathing a minimum of 6", and nail upwards through sheathing into purlin with a minimum of 8-8d (0.131"x2.5") common nails.
- Effects of not providing sheathing below a valley set must be evaluated by the building designer.

This drawing applies to valleys with the following conditions:

- Spans (distance between heels) 40'-0" or less
- Maximum valley height: 14'-0"
- Maximum mean roof height: 30 feet
- ASCE 7-05, 120 mph, Enclosed, Cat II, Exp B, I=1.0, Kzt=1.0
- Or ASCE 7-10, ASCE 7-16, or ASCE 7-22 150 mph, Enclosed, Exp B, Kzt=1.0
- Or ASCE 7-10, ASCE 7-16, or ASCE 7-22 125 mph, Enclosed, Exp C, Kzt=1.0
- Or ASCE 7-10, ASCE 7-16, or ASCE 7-22 100 mph, Part. Enc., Exp C, Kzt=1.0
- Or ASCE 7-10, ASCE 7-16, or ASCE 7-22 110 mph, Enclosed, Exp D, Kzt=1.0

CRIPPLE, BRACING, & BLOCKING NOTES

- 2x4 continuous lateral restraint (CLR) min. is required for cripples 5'-0" to 10'-0" long nailed w/ 2 -10d (0.148"x3") common nails. Or 2x4 "T" or scab reinforcement nailed to flat edge of cripple with 10d (0.128"x3.0") box nails at 6" o.c. "T" or scab must be 90% of cripple length. Cripples over 10'-0" long require two CLR's or both faces w/ "T" or scab.
- Use stress graded lumber & box or common nails.
- Narrow edge of cripple can face ridge or rafter, as long as the proper number of nails are installed into ridge board
- Install blocking under rafter if sleepers are not used.
- Install blocking under cripples if cripples fall between lower truss top chords and lateral bracing is not used.
- Apply all nailing in accordance to current NDS requirements.



155 Harlem Ave
North Building, 4th Floor
Glenview, IL 60025

WARNING: READ AND FOLLOW ALL NOTES ON THIS DRAWING
IMPORTANT: FURNISH THIS DRAWING TO ALL CONTRACTORS INCLUDING THE INSTALLERS.

Trusses require extreme care in fabricating, handling, shipping, installing and bracing. Refer to and follow the latest edition of BCSI (Building Component Safety Information, by TPI and SBCA) for safety practices prior to performing these functions. Installers shall provide temporary bracing per BCSI. Unless noted otherwise, top chord shall have properly attached structural sheathing and bottom chord shall have a properly attached rigid ceiling. Locations shown for permanent lateral restraint of webs shall have bracing installed per BCSI sections B3, B7 or B10, as applicable. Apply plates to each face of truss and position as shown above and on the Joint Details, unless noted otherwise. Refer to drawings 160A-Z for standard plate positions.

Alpine, a division of ITW Building Components Group Inc. shall not be responsible for any deviation from this drawing, any failure to build the truss in conformance with ANSI/TPI 1, or for handling, shipping, installation & bracing of trusses.

A seal on this drawing or cover page listing this drawing, indicates acceptance of professional engineering responsibility solely for the design shown. The suitability and use of this drawing for any structure is the responsibility of the Building Designer per ANSI/TPI 1 Sec.2.

For more information see this job's general notes page and these web sites:
ALPINE: www.alpineitw.com; TPI: www.tpinet.org; SBCA: www.sbcacomponents.com; ICC: www.iccsafe.org

	(A)	(B)	(**)		
TC LL	20	30	40	54	REF VALLEY FRAMING
TC DL	10	20	7	7	DATE 07/03/2023
BC DL	0	0	0	0	DRWG VALCONVF0723
BC LL	0	0	0	0	
TOT. LD.	30	50	47	61	
DUR. FAC.	1.25/1.15				
SPACING SEE ABOVE					