

SCAB 2X4 OVERHANG DETAIL

ASCE 7-05 120 mph wind, CAT II, EXP C,
30.00 ft mean hgt, located anywhere in roof,
wind TC DL=4.2 psf, wind BC DL=6.0 psf, Kzt = 1.00.

ASCE 7-10, ASCE 7-16, & ASCE 7-22 160 mph wind, EXP C,
Or 140 mph wind, EXP D, 30.00 ft mean hgt, located anywhere
in roof, wind TC DL=4.2 psf, wind BC DL=6.0 psf, Kzt = 1.00.

Minimum 2X4 scab, same grade and species as top chord designated on Engineer's sealed design and three times the overhang length. Attach overhang scab to one face of top chord with 10d box or Gun (0.128"x3.0", min) nails at 8" o.c. plus clusters of four nails where shown in figure below (*).

NOTE: #2 is the minimum lumber grade allowed for all species.

NOTE: Add 225# uplift (max.) to reported truss uplift for wall connections.

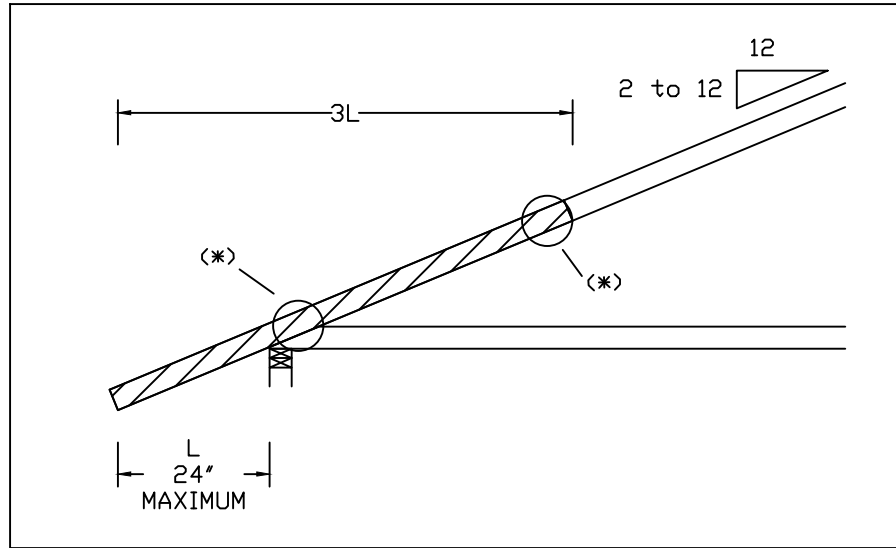

155 Harlem Ave
North Building, 4th Floor
Glenview, IL 60025

WARNING: READ AND FOLLOW ALL NOTES ON THIS DRAWING!
IMPORTANT: FURNISH THIS DRAWING TO ALL CONTRACTORS INCLUDING THE INSTALLERS.

Trusses require extreme care in fabricating, handling, shipping, installing and bracing. Refer to and follow the latest edition of BCSI (Building Component Safety Information, by TPI and SBCA) for safety practices prior to performing these functions. Installers shall provide temporary bracing per BCSI. Unless noted otherwise, top chord shall have properly attached structural sheathing and bottom chord shall have a properly attached rigid ceiling. Locations shown for permanent lateral restraint of webs shall have bracing installed per BCSI sections B3, B7 or B10, as applicable. Apply plates to each face of truss and position as shown above and on the Joint Details, unless noted otherwise. Refer to drawings 150A-Z for standard plate positions.

Alpine, a division of ITW Building Components Group Inc. shall not be responsible for any deviation from this drawing, any failure to build the truss in conformance with ANSI/TPI 1, or for handling, shipping, installation & bracing of trusses.

A seal on this drawing or cover page listing this drawing, indicates acceptance of professional engineering responsibility solely for the design shown. The suitability and use of this drawing for any structure is the responsibility of the Building Designer per ANSI/TPI 1 Sec.2.

For more information see this Job's general notes page and these web sites:
ALPINE: www.alpineitw.com TPI: www.tpinst.org SBCA: www.sbcacomponents.com ICC: www.iccsafe.org

TOTAL TOP CHORD LOAD NOT TO EXCEED 40 PSF (DEAD PLUS LIVE)	REF 2X4 SCAB O.H.
	DATE 06/23/2023
	DRWG DHSCB2X40623
DUR. FAC. 1.15/1.25	
SPACING 24"	