

* Hip Frame with Ledger Scab

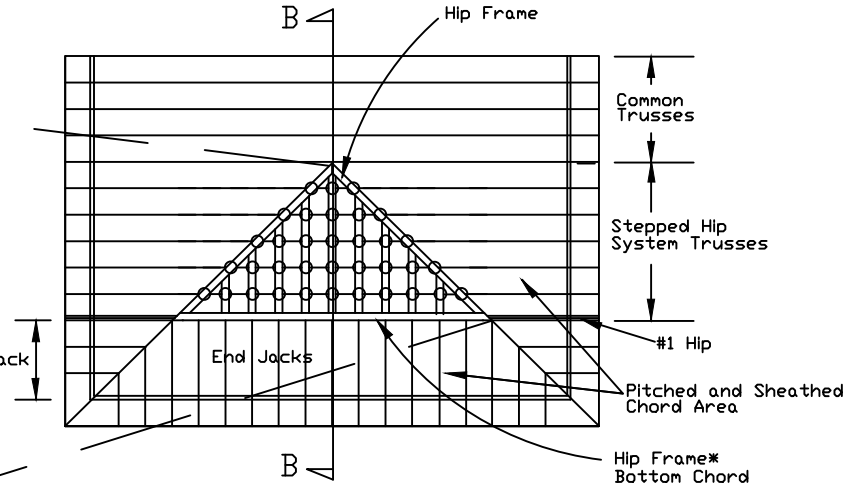
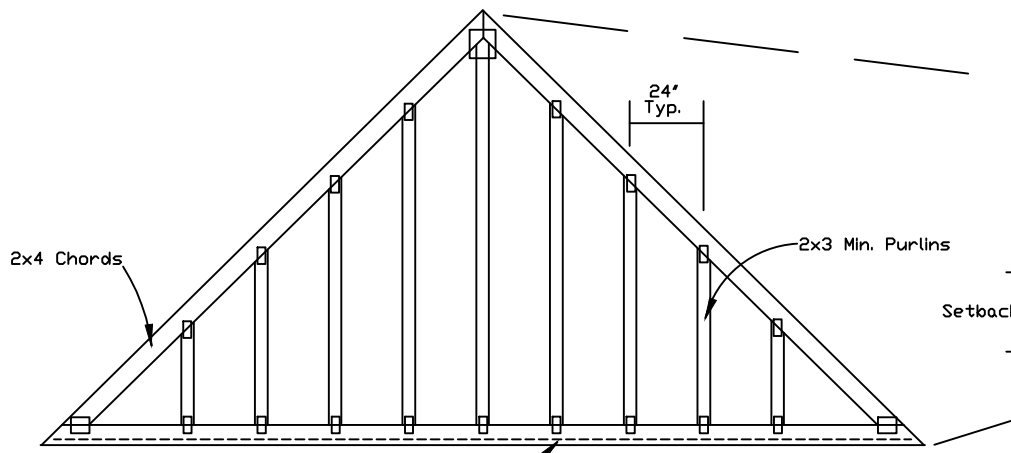

O - Attach hip frame to flat chords of stepped hips at all overlapping points with 2-10d common (0.148"x3.0") nails. Bottom chord of hip frame to be attached to ledger scab with 10d common (0.148"x3.0") nails @ 6' o.c. maximum spacing.

* Hip frame lumber is SPF #2 or better. Refer to Engineer's Drawing for lumber and plates.

'R' Hip frame chords may be trimmed up to 15' to fit. Purlins must be intact and properly attached.

Maximum of 2 plies allowed for #1 hip girder. See Engineer's sealed design for setback, lumber, plating, loading, and duration factor required.

Use this detail for ASCE 7-10, ASCE 7-16, & ASCE 7-22, 115 mph, 30' M.H., Enclosed, Exp C, Category II, Wind TC, DL=4.2 psf, Kzt=1.00

Ledger scab shall be SPF #2 or better (Min. SG = 0.42). See Ledger Scab Size Table below for minimum scab size. Attach ledger scab to one face of the flat top chord of the #1 hip truss with 10d common (0.148"x3.0") nails @ 6.0' o.c. maximum spacing.

TC Size	# of Plies	Roof Pitch (p)	Scab Size
2x4	1	4/12 ≤ p ≤ 12/12	2x4
2x6	1	4/12 ≤ p ≤ 12/12	2x6
2x4	2	4/12 ≤ p ≤ 7/12	2x4
2x6	2	4/12 ≤ p ≤ 7/12	2x6
2x4	2	7/12 < p ≤ 12/12	2x6
2x6	2	7/12 < p ≤ 12/12	2x8

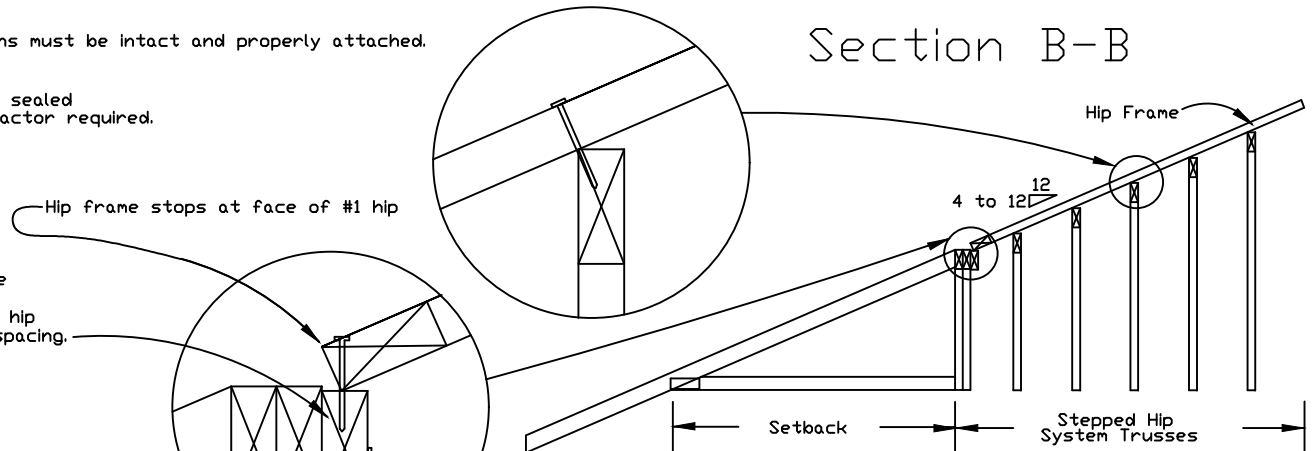

Hip Frame - provided by truss manufacturer. Hip frame is designed to provide bracing for flat top chords of hip frame system where indicated. Flat top chords of stepped hip system must be SPF lumber or better (Min. SG = 0.42). Structural panels must be properly attached directly to hip frame purlins.

WARNING: READ AND FOLLOW ALL NOTES ON THIS DRAWING. IMPORTANT: FURNISH THIS DRAWING TO ALL CONTRACTORS INCLUDING THE INSTALLERS.

Trusses require extreme care in fabricating, handling, shipping, installing and bracing. Refer to and follow the latest edition of BCSI (Building Component Safety Information, by TPI and SBCA) for safety practices prior to performing these functions. Installers shall provide temporary bracing per BCSI. Unless noted otherwise, top chord shall have properly attached structural sheathing and bottom chord shall have a properly attached rigid ceiling. Locations shown for permanent lateral restraint of webs shall have bracing installed per BCSI sections B3, B7 or B10, as applicable. Apply plates to each face of truss and position as shown above and on the Joint Details, unless noted otherwise. Refer to drawings 160A-Z for standard plate positions.

Alpine, a division of ITW Building Components Group Inc. shall not be responsible for any deviation from this drawing, any failure to build the truss in conformance with ANSI/TPI 1, or for handling, shipping, installation & bracing of trusses.

A seal on this drawing or cover page listing this drawing, indicates acceptance of professional engineering responsibility solely for the design shown. The suitability and use of this drawing for any structure is the responsibility of the Building Designer per ANSI/TPI 1 Sec.2.

For more information see this job's general notes page and these web sites:
ALPINE: www.alpineitw.com; TPI: www.tpinst.org; SBCA: www.sbcacomponents.com; ICC: www.iccsafe.org



155 Harlem Ave
North Building, 4th Floor
Glenview, IL 60025

REF HIP FRAME		
DATE	06/23/2023	
DRWG	HIPFRSCAB0623	
TC LL	42.00	PSF
TC DL	10.00	PSF
TC TL	52.00	PSF
DUR. FAC.	1.15	