

VERTICAL GRAINED SOLID SAW TRIMMABLE END DETAIL

TRIMSAWN

rev - Nov 2020
by - MB

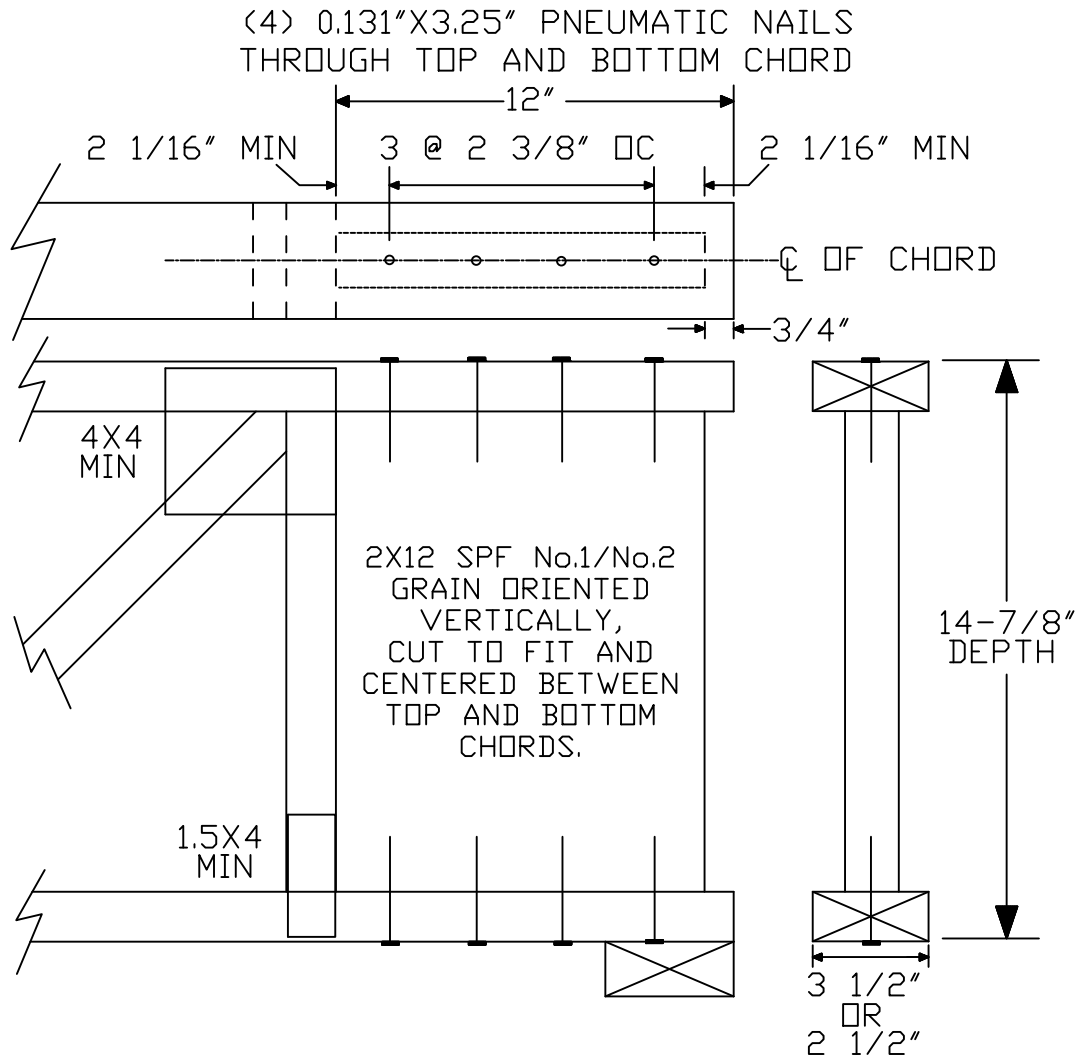

THIS TRUSS DETAIL APPLIES TO 4X2 AND 3X2 TRUSSES ONLY.

MAX SPAN NOT TO EXCEED 27'.

THIS TRUSS END MAY BE TRIMMED UP TO 12". DO NOT CUT METAL CONNECTOR PLATES.

REFER TO ENGINEER'S SEALED DESIGN REFERENCING THIS DETAIL FOR LUMBER, PLATES, AND OTHER INFORMATION NOT SHOWN.

PERIMETER BANDS, BLOCKING, AND CONNECTIONS ARE TO BE DESIGNED BY BUILDING DESIGNER.

PLATE AT THE JOINT OF THE TOP CHORD AND INNER VERTICAL AT TRIMMABLE END MUST BE AT LEAST 4X4.

PLATE AT THE JOINT OF THE BOTTOM CHORD AND INNER VERTICAL AT TRIMMABLE END MUST BE AT LEAST 1.5X4.

THE END PANELS ON THE TRIMMABLE END DESIGN DRAWING MAY BE REPLACED WITH THIS DETAIL.

MAXIMUM UNFACTORED LOADING IS 110 PLF.

www.alpineitw.com