

VERTICAL GRAINED SOLID SAW TRIMMABLE END DETAIL

TRIMSAWN

rev - Nov 2021
by - JB



Markham, ON / Coquitlam, BC / Gatineau, QC

(4) 0.152"X3.0" COMMON SPIRAL NAILS
THROUGH TOP AND BOTTOM CHORD

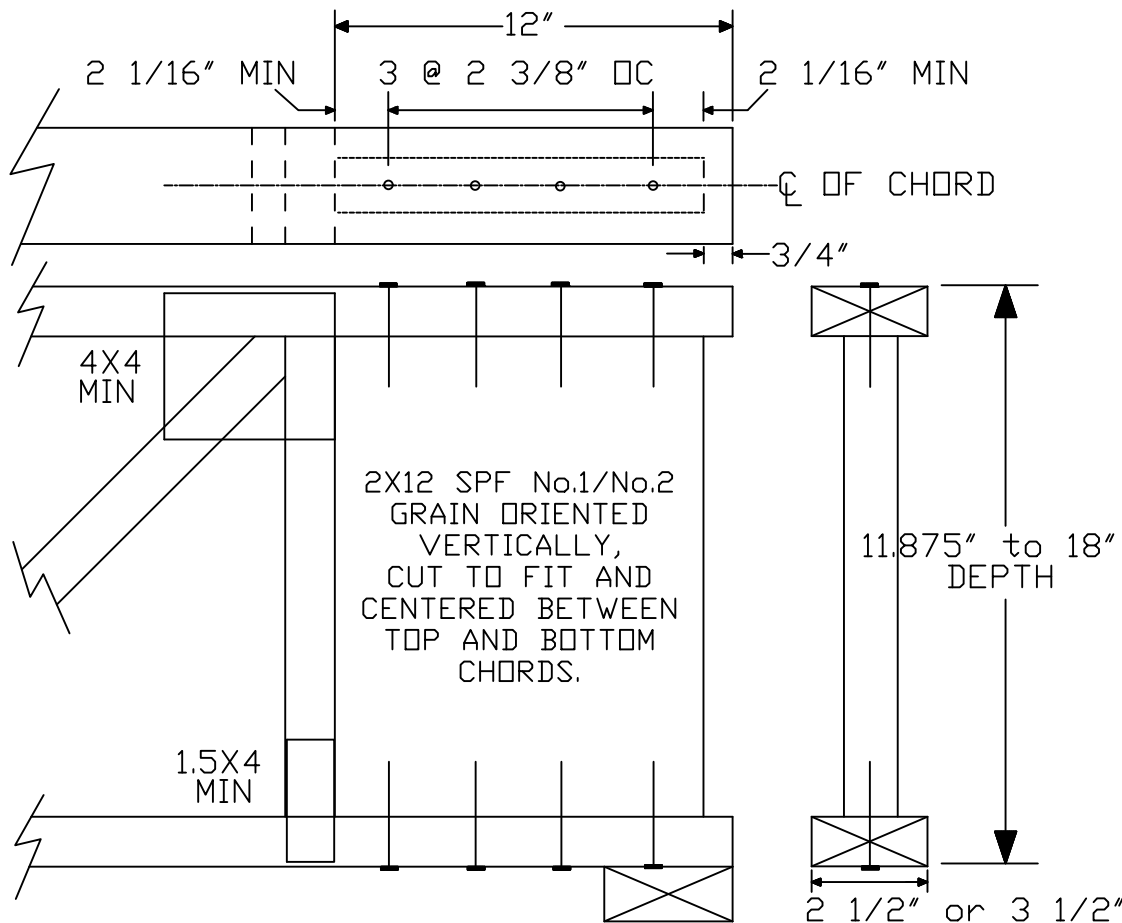

THIS TRUSS DETAIL APPLIES TO 4X2 AND 3X2 TRUSSES ONLY.

MAX SPAN NOT TO EXCEED 27'.

THIS TRUSS END MAY BE TRIMMED UP TO 12". DO NOT CUT METAL CONNECTOR PLATES.

REFER TO ENGINEER'S SEALED DESIGN REFERENCING THIS DETAIL FOR LUMBER, PLATES, AND OTHER INFORMATION NOT SHOWN.

PERIMETER BANDS, BLOCKING, AND CONNECTIONS ARE TO BE DESIGNED BY BUILDING DESIGNER.

PLATE AT THE JOINT OF THE TOP CHORD AND INNER VERTICAL AT TRIMMABLE END MUST BE AT LEAST 4X4.

PLATE AT THE JOINT OF THE BOTTOM CHORD AND INNER VERTICAL AT TRIMMABLE END MUST BE AT LEAST 1.5X4.

THE END PANELS ON THE TRIMMABLE END DESIGN DRAWING MAY BE REPLACED WITH THIS DETAIL.

www.alpineitw.com

CCMC #12182-L, 12802-L, 13124-L

WARNING TRUSSES REQUIRE EXTREME CARE IN FABRICATING, HANDLING, SHIPPING, INSTALLING AND BRACING. REFER TO BCSC-IBC HANDLING, INSTALLING, RESTRAINING AND BRACING, JOINTLY PRODUCED BY TPIC, TPI AND SBGA, AND AVAILABLE AT WWW.SBGAINDUSTRY.COM/BCSC-CANADA FOR BEST PRACTICES PRIOR TO PERFORMING THESE FUNCTIONS. UNLESS OTHERWISE INDICATED, TOP CHORD SHALL HAVE PROPERLY ATTACHED STRUCTURAL PANELS AND BOTTOM CHORD SHALL HAVE A PROPERLY ATTACHED RIGID CEILING. IMPORTANT! FURNISH A COPY OF THIS DESIGN TO THE INSTALLATION CONTRACTOR. ALPINE SYSTEMS CORPORATION SHALL NOT BE RESPONSIBLE FOR ANY DEVIATION FROM THIS DESIGN. ANY FAILURE TO BUILD THE TRUSSES IN CONFORMANCE WITH TPIC DESIGN STANDARDS, HANDLING, SHIPPING, INSTALLING AND BRACING OF TRUSSES. DESIGN CONFORMS WITH APPLICABLE PROVISIONS OF CSA (CANADIAN STANDARDS ASSOCIATION), IBC/C, AND TPIC. ALPINE CONNECTORS ARE MADE OF 300A ASTM A653 GRA9 GALV. STEEL. EXCEPT AS NOTED, APPLY CONNECTORS TO EACH FACE OF TRUSS AND, UNLESS OTHERWISE LOCATED IN THIS DESIGN, POSITION CONNECTORS PER DRAWINGS 160 A-Z. THE SEAL ON THIS DRAWING INDICATES ACCEPTANCE OF PROFESSIONAL ENGINEERING RESPONSIBILITY SOLELY FOR THE TRUSS COMPONENT DESIGN SHOWN. THE SUITABILITY AND USE OF THIS COMPONENT FOR ANY SPECIFIC BUILDING IS THE RESPONSIBILITY OF THE BUILDING DESIGNER, PER APPLICABLE TPIC DESIGN STANDARD.