

Full Notch in SY42 Top or Bottom Chord Repair Detail

This drawing specifies repair of SY42 truss with notch in top or bottom chord.

The use of this detail is only acceptable if the notch and truss meet these requirements:

- *Single ply SY42 truss.
- *Notch may be greater than 1 $\frac{3}{4}$ " deep or full depth.
- *Notch shall not be longer than 6"
- *Connector plates are not to be cut or damaged
- *Notch shall not be located in chase area
- *Chord shall be free of lumber defects for 12" to each side of notch.
- *Only one notch permitted per truss.
- *Webs are not to be notched, drilled, or cut.
- *Damage to chord member, regardless of shape or cause, shall adhere to requirements specified on this detail.

Scab Attachment and Requirements

- *2x6 scab fastened to one face of truss, centered on location of cut-out section. Refer to "MAXIMUM ALLOWABLE FORCE AT NOTCH" chart for required scab length
- *Scab shall be same species and grade or better as cut chord
- *Fasten scab using an AFG-01 adhesive (e.g. PL 400) with surfaces prepared per adhesive manufacturer's specs.
- *Scab shall not be used as ledger to support tie in loads.
- *Nail scab using 10d(0.131"x3.0") nails in 1 row at 3" oc for full length of scab. With one additional nail in each overlapping web.
- *Scab is not to be notched, drilled, or cut.

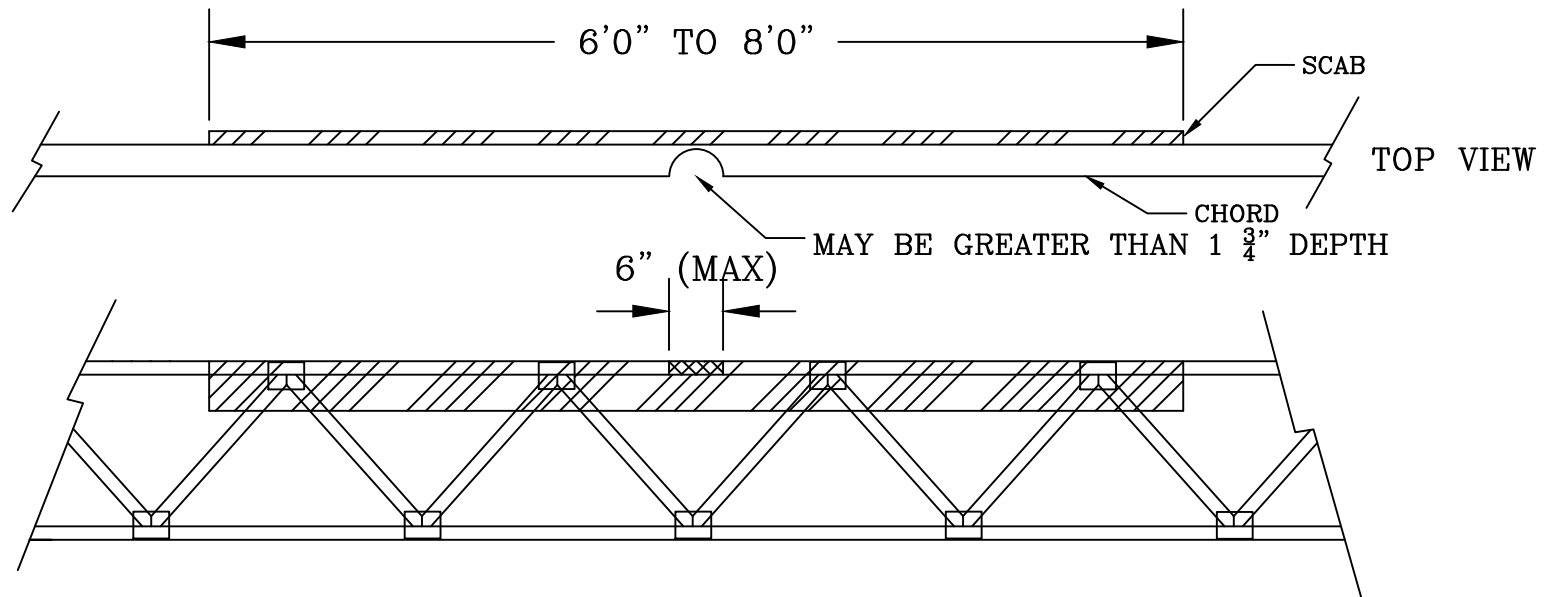

MAXIMUM ALLOWABLE CHORD FORCE AT NOTCH (LBS)		
L	6'0"	8'0"
DF	1067	1455
HF	924	1260
SP	1166	1590
SPF	902	1230



WARNING: READ AND FOLLOW ALL NOTES ON THIS DRAWING! IMPORTANT: FURNISH THIS DRAWING TO ALL CONTRACTORS INCLUDING THE INSTALLERS.

Trusses require extreme care in fabricating, handling, shipping, installing and bracing. Refer to and follow the latest edition of BCSI (Building Component Safety Information, by TPI and SBCA) for safety practices prior to performing these functions. Installers shall provide temporary bracing per BCSI. Unless noted otherwise, top chord shall have properly attached structural sheathing and bottom chord shall have a properly attached rigid ceiling. Locations shown for permanent lateral restraint of webs shall have bracing installed per BCSI sections B3, B7 or B10, as applicable. Apply plates to each face of truss and position as shown above and on the Joint Details, unless noted otherwise. Refer to drawings 150A-Z for standard plate positions.

Alpine, a division of ITW Building Components Group Inc. shall not be responsible for any deviation from this drawing, any failure to build the truss in conformance with ANSI/TPI 1, or for handling, shipping, installation & bracing of trusses.

A seal on this drawing or cover page listing this drawing, indicates acceptance of professional engineering responsibility solely for the design shown. The suitability and use of this drawing for any structure is the responsibility of the Building Designer per ANSI/TPI 1 Sec.2.

For more information see this Job's general notes page and these web sites:
ALPINE: www.alpineitw.com; TPI: www.tpinst.org; SBCA: www.sbcacomponents.com; ICC: www.iccsafe.org

TC LL	PSF	REF	---
TC DL	PSF	DATE	05/01/2020
BC DL	PSF	DRWG	REPSY42FN0520
BC LL	PSF	-ENG	
TOT. LD.	PSF		
DUR. FAC.			
SPACING			