

Piggyback Detail - ASCE 7-10: 180 mph, 30' Mean Hgt, Partially Enclosed, Exp. C, Kzt=1.00

180 mph Wind, 30.00 ft Mean Hgt, ASCE 7-10, Part. Enclosed Bldg. located anywhere in roof, Exp C, Wind DL= 5.0 psf (min), Kzt=1.0.
 Or 160 mph wind, 30.00 ft Mean Hgt, ASCE 7-10, Part. Enclosed Bldg. located anywhere in roof, Exp D, wind DL= 5.0 psf (min), Kzt=1.0.

Note: Top chords of trusses supporting piggyback cap trusses must be adequately braced by sheathing or purlins. The building Engineer of Record shall provide diagonal bracing or any other suitable anchorage to permanently restrain purlins, and lateral bracing for out of plane loads over gable ends.

Maximum truss spacing is 24' o.c. detail is not applicable if cap supports additional loads such as cupola, steeple, chimney or drag strut loads.

** Refer to Engineer's sealed truss design drawing for piggyback and base truss specifications.

Piggyback cap truss slant nailed to all top chord purlin bracing with (2) 16d box nails (0.135"x3.5") and secure top chord with 2x4 #3 grade scab (1 side only at each end) attached with 2 rows of 10d box nails (0.128"x3") at 4' o.c.

++ Flat top chord purlins required at both ends and at a maximum of 24' intervals unless otherwise noted on base truss design drawing. Attach purlin bracing to the flat top chord using a minimum of (2) 16d box nails (0.135"x3.5").

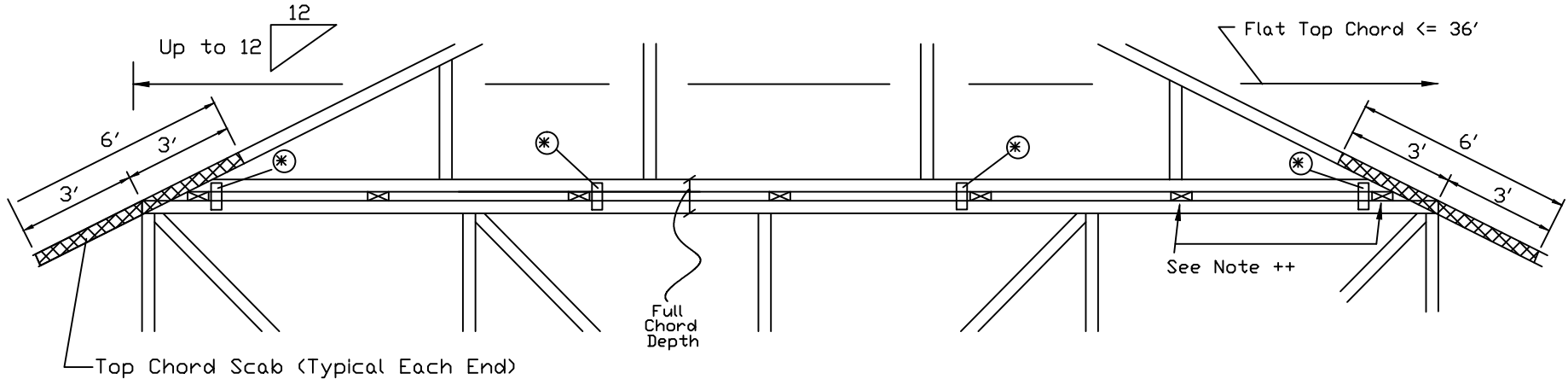

* In addition, provide connection with one of the following methods:

<p>Trulox Use 3X8 Trulox plates for 2x4 chord member, and 3X10 Trulox plates for 2x6 and larger chord members. Attach to each face @ 8' o.c. with (4) 0.120"x1.375' nails into cap bottom chord and (4) in base truss top chord. Trulox plates may be staggered 4' o.c. front to back faces.</p>	<p>28PB Wave Piggyback Plate One 28PB wave piggyback plate to each face @ 8' o.c. Attach teeth to piggyback at time of fabrication. Attach to supporting truss with (4) 0.120"x1.375' nails per face per ply. Piggyback plates may be staggered 4' o.c. front to back faces.</p>
<p>APA Rated Gusset 8"x8"x7/16' (min) APA rated sheathing gussets (each face). Attach @ 8' o.c. with (8) 6d common (0.113"x2") nails per gusset, (4) in cap bottom chord and (4) in base truss top chord. Gussets may be staggered 4' o.c. front to back faces.</p>	<p>2x4 Vertical Scabs 2x4 SPF #2, full chord depth scabs (each face). Attach @ 8' o.c. with (6) 10d box nails (0.128"x3") per scab, (3) in cap bottom chord and (3) in base truss top chord. Scabs may be staggered 4' o.c. front to back faces.</p>

*****WARNING*** READ AND FOLLOW ALL NOTES ON THIS DRAWING
 IMPORTANT FURNISH THIS DRAWING TO ALL CONTRACTORS INCLUDING THE INSTALLERS.**

Trusses require extreme care in fabricating, handling, shipping, installing and bracing. Refer to and follow the latest edition of BCSI (Building Component Safety Information, by TPI and SBCA) for safety practices prior to performing these functions. Installers shall provide temporary bracing per BCSI. Unless noted otherwise, top chord shall have properly attached structural sheathing and bottom chord shall have a properly attached rigid ceiling. Locations shown for permanent lateral restraint of webs of truss and position as shown above and on the Joint Details, unless noted otherwise. Refer to drawings 160A-Z for standard plate positions.

Alpine, a division of ITW Building Components Group Inc. shall not be responsible for any deviation from this drawing, any failure to build the truss in conformance with ANSI/TPI 1, or for handling, shipping, installation & bracing of trusses.

A seal on this drawing or cover page listing this drawing, indicates acceptance of professional engineering responsibility solely for the design shown. The suitability and use of this drawing for any structure is the responsibility of the Building Designer per ANSI/TPI 1 Sec.2.

For more information see this Job's general notes page and these web sites:
 ALPINE: www.alpineitw.com TPI: www.tpinst.org SBCA: www.sbcacomponents.com ICC: www.iccsafe.org

ALPINE
 AN ITW COMPANY

155 Harlem Ave
 North Building, 4th Floor
 Glenview, IL 60025

REF PIGGYBACK

DATE 10/01/14

DRWG PB180101014

SPACING 24.0"