

Gable Stud Reinforcement Detail

ASCE 7-16: 115 mph Wind Speed, 15' Mean Height, Enclosed, Exposure C, Kzt = 1.00

| Max Gable Vertical Length | 2x4 Gable Vertical | | Brace Grade | No Braces | (1) 1x4 "L" Brace * | | (1) 2x4 "L" Brace * | | (2) 2x4 "L" Brace ** | | (1) 2x6 "L" Brace * | | (2) 2x6 "L" Brace ** | |
|---------------------------|--------------------|---------|-------------|-----------|---------------------|---------|---------------------|---------|----------------------|---------|---------------------|---------|----------------------|---------|
| | Spacing | Species | | | Group A | Group B | Group A | Group B | Group A | Group B | Group A | Group B | Group A | Group B |
| | 24" o.c. | SPF | #1 / #2 | #1 / #2 | 4' 11" | 8' 5" | 8' 9" | 9' 11" | 10' 4" | 11' 10" | 12' 4" | 14' 0" | 14' 0" | 14' 0" |
| #3 | | | | 4' 8" | 8' 1" | 8' 7" | 9' 10" | 10' 3" | 11' 9" | 12' 2" | 14' 0" | 14' 0" | 14' 0" | 14' 0" |
| Stud | | | | 4' 8" | 8' 0" | 8' 6" | 9' 10" | 10' 3" | 11' 9" | 12' 2" | 14' 0" | 14' 0" | 14' 0" | 14' 0" |
| HF | | | #1 | 4' 8" | 6' 11" | 7' 4" | 9' 2" | 9' 10" | 11' 9" | 12' 2" | 14' 0" | 14' 0" | 14' 0" | 14' 0" |
| | | | #2 | 5' 2" | 8' 7" | 8' 10" | 10' 1" | 10' 6" | 12' 0" | 12' 5" | 14' 0" | 14' 0" | 14' 0" | 14' 0" |
| | | | Standard | 4' 8" | 8' 0" | 8' 6" | 9' 10" | 10' 3" | 11' 9" | 12' 2" | 14' 0" | 14' 0" | 14' 0" | 14' 0" |
| SP | | #1 | #1 | 4' 11" | 8' 5" | 8' 9" | 9' 11" | 10' 4" | 11' 10" | 12' 4" | 14' 0" | 14' 0" | 14' 0" | 14' 0" |
| | | | #2 | 4' 11" | 8' 5" | 8' 9" | 9' 11" | 10' 4" | 11' 10" | 12' 4" | 14' 0" | 14' 0" | 14' 0" | 14' 0" |
| | | | Standard | 4' 10" | 7' 3" | 7' 9" | 9' 8" | 10' 3" | 11' 9" | 12' 3" | 14' 0" | 14' 0" | 14' 0" | 14' 0" |
| | | DFL | #1 | 4' 10" | 7' 3" | 7' 9" | 9' 8" | 10' 3" | 11' 9" | 12' 3" | 14' 0" | 14' 0" | 14' 0" | 14' 0" |
| | | | #2 | 4' 10" | 7' 3" | 7' 9" | 9' 8" | 10' 3" | 11' 9" | 12' 3" | 14' 0" | 14' 0" | 14' 0" | 14' 0" |
| | | | Standard | 4' 8" | 6' 5" | 6' 10" | 8' 7" | 9' 2" | 11' 7" | 12' 2" | 13' 5" | 14' 0" | 14' 0" | 14' 0" |
| 16" o.c. | SPF | #1 / #2 | #1 / #2 | 5' 8" | 9' 8" | 10' 0" | 11' 5" | 11' 10" | 13' 7" | 14' 0" | 14' 0" | 14' 0" | 14' 0" | |
| | | | #3 | 5' 5" | 9' 6" | 10' 0" | 11' 3" | 11' 8" | 13' 5" | 14' 0" | 14' 0" | 14' 0" | 14' 0" | |
| | | | Stud | 5' 5" | 9' 6" | 9' 10" | 11' 3" | 11' 8" | 13' 5" | 14' 0" | 14' 0" | 14' 0" | 14' 0" | |
| | | HF | #1 | 5' 5" | 9' 6" | 9' 10" | 11' 3" | 11' 8" | 13' 5" | 14' 0" | 14' 0" | 14' 0" | 14' 0" | |
| | | | #2 | 5' 11" | 9' 9" | 10' 2" | 11' 6" | 12' 0" | 13' 8" | 14' 0" | 14' 0" | 14' 0" | 14' 0" | |
| | | | Standard | 5' 5" | 8' 5" | 9' 0" | 11' 3" | 11' 8" | 13' 5" | 14' 0" | 14' 0" | 14' 0" | 14' 0" | |
| | SP | #1 | #1 | 5' 11" | 9' 9" | 10' 2" | 11' 6" | 12' 0" | 13' 8" | 14' 0" | 14' 0" | 14' 0" | 14' 0" | |
| | | | #2 | 5' 8" | 9' 8" | 10' 0" | 11' 5" | 11' 10" | 13' 7" | 14' 0" | 14' 0" | 14' 0" | 14' 0" | |
| | | | Standard | 5' 6" | 8' 11" | 9' 6" | 11' 4" | 11' 9" | 13' 6" | 14' 0" | 14' 0" | 14' 0" | 14' 0" | |
| | | DFL | #1 | 5' 6" | 8' 11" | 9' 6" | 11' 4" | 11' 9" | 13' 6" | 14' 0" | 14' 0" | 14' 0" | 14' 0" | |
| | | | #2 | 5' 5" | 7' 10" | 8' 4" | 10' 6" | 11' 2" | 13' 5" | 14' 0" | 14' 0" | 14' 0" | 14' 0" | |
| | | | Standard | 5' 5" | 7' 10" | 8' 4" | 10' 6" | 11' 2" | 13' 5" | 14' 0" | 14' 0" | 14' 0" | 14' 0" | |
| 12" o.c. | SPF | #1 / #2 | #1 / #2 | 6' 3" | 10' 7" | 11' 0" | 12' 7" | 13' 0" | 13' 7" | 14' 0" | 14' 0" | 14' 0" | 14' 0" | |
| | | | #3 | 5' 11" | 10' 6" | 10' 10" | 12' 5" | 12' 10" | 14' 0" | 14' 0" | 14' 0" | 14' 0" | 14' 0" | |
| | | | Stud | 5' 11" | 10' 6" | 10' 10" | 12' 5" | 12' 10" | 14' 0" | 14' 0" | 14' 0" | 14' 0" | 14' 0" | |
| | | HF | #1 | 5' 11" | 9' 9" | 10' 5" | 12' 5" | 12' 10" | 14' 0" | 14' 0" | 14' 0" | 14' 0" | 14' 0" | |
| | | | #2 | 6' 6" | 10' 9" | 11' 12" | 12' 8" | 13' 2" | 14' 0" | 14' 0" | 14' 0" | 14' 0" | 14' 0" | |
| | | | Standard | 5' 11" | 9' 9" | 10' 5" | 12' 5" | 12' 10" | 14' 0" | 14' 0" | 14' 0" | 14' 0" | 14' 0" | |
| | SP | #1 | #1 | 6' 6" | 10' 9" | 11' 12" | 12' 8" | 13' 2" | 14' 0" | 14' 0" | 14' 0" | 14' 0" | 14' 0" | |
| | | | #2 | 6' 3" | 10' 7" | 11' 0" | 12' 7" | 13' 0" | 14' 0" | 14' 0" | 14' 0" | 14' 0" | 14' 0" | |
| | | | Standard | 6' 1" | 10' 3" | 10' 11" | 12' 6" | 12' 11" | 14' 0" | 14' 0" | 14' 0" | 14' 0" | 14' 0" | |
| | | DFL | #1 | 6' 1" | 10' 3" | 10' 11" | 12' 6" | 12' 11" | 14' 0" | 14' 0" | 14' 0" | 14' 0" | 14' 0" | |
| | | | #2 | 6' 1" | 10' 3" | 10' 11" | 12' 6" | 12' 11" | 14' 0" | 14' 0" | 14' 0" | 14' 0" | 14' 0" | |
| | | | Standard | 5' 11" | 9' 1" | 9' 8" | 12' 1" | 12' 10" | 14' 0" | 14' 0" | 14' 0" | 14' 0" | 14' 0" | |

Bracing Group Species and Grades:

| Group A: | | | |
|-------------------|----------|------------------|----------|
| Spruce-Pine-Fir | | Hem-Fir | |
| #1 / #2 | Standard | #2 | Stud |
| #3 | Stud | #3 | Standard |
| Douglas Fir-Larch | | Southern Pine*** | |
| #3 | | #3 | |
| Stud | | Stud | |
| Standard | | Standard | |

| Group B: | |
|-------------------|--|
| Hem-Fir | |
| #1 & Btr | |
| #1 | |
| Douglas Fir-Larch | |
| #1 | |
| #2 | |
| Southern Pine*** | |
| #1 | |
| #2 | |

1x4 Braces shall be SRB (Stress-Rated Board).
 ***For 1x4 So. Pine use only Industrial 55 or Industrial 45 Stress-Rated Boards. Group B values may be used with these grades.

Gable Truss Detail Notes:
 Wind Load deflection criterion is L/240.
 Provide uplift connections for 30 plf over continuous bearing (5 psf TC Dead Load).
 Gable end supports load from 4' 0" outlookers with 2' 0" overhang, or 12' plywood overhang.

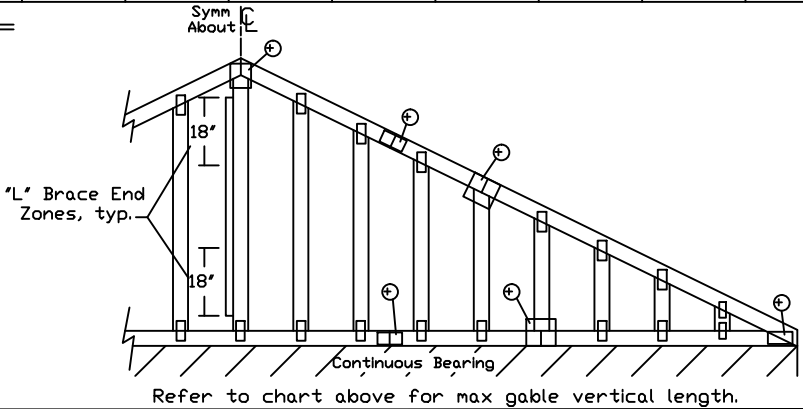
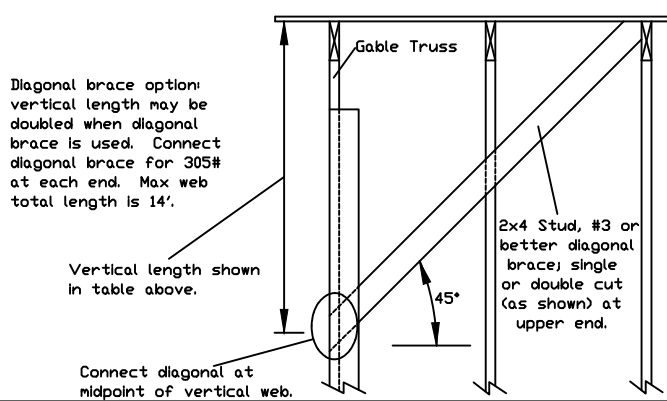

Attach "L" braces with 10d (0.128"x3.0" min) nails.
 * For (1) "L" brace: space nails at 2' o.c. in 18' end zones and 4' o.c. between zones.
 ** For (2) "L" braces: space nails at 3' o.c. in 18' end zones and 6' o.c. between zones.
 "L" bracing must be a minimum of 80% of web member length.

| Gable Vertical Plate Sizes | |
|--|------------|
| Vertical Length | No Splice |
| Less than 4' 0" | 1X4 or 2X3 |
| Greater than 4' 0", but less than 11' 6" | 2X4 |
| Greater than 11' 6" | 3X4 |

+ Refer to common truss design for peak, splice, and heel plates.

Refer to the Building Designer for conditions not addressed by this detail.



*****WARNING*** READ AND FOLLOW ALL NOTES ON THIS DRAWING**
*****IMPORTANT*** FURNISH THIS DRAWING TO ALL CONTRACTORS INCLUDING THE INSTALLERS.**
 Trusses require extreme care in fabricating, handling, shipping, installing and bracing. Refer to and follow the latest edition of BCSI (Building Component Safety Information, by TPI and SBCA) for safety practices prior to performing these functions. Installers shall provide temporary bracing per BCSI. Unless noted otherwise, top chord shall have properly attached structural sheathing and bottom chord shall have a properly attached rigid ceiling. Locations shown for permanent lateral restraint of webs shall have bracing installed per BCSI sections B3, B7 or B10, as applicable. Apply plates to each face of truss and position as shown above and on the Joint Details, unless noted otherwise. Refer to drawings 150A-Z for standard plate positions.
 Alpine, a division of ITW Building Components Group Inc. shall not be responsible for any deviation from this drawing, any failure to build the truss in conformance with ANSI/TPI 1, or for handling, shipping, installation & bracing of trusses.
 A seal on this drawing or cover page listing this drawing, indicates acceptance of professional engineering responsibility solely for the design shown. The suitability and use of this drawing for any structure is the responsibility of the Building Designer per ANSI/TPI 1 Sec.2.
 For more information see this Job's general notes page and these web sites:
 ALPINE: www.alpineitw.com; TPI: www.tpinst.org; SBCA: www.sbcacomponents.com; ICC: www.iccsafe.org

MAX. TOT. LD. 60 PSF

MAX. SPACING 24.0"

| | |
|------|-------------------|
| REF | ASCE7-16-GAB11515 |
| DATE | 01/26/2018 |
| DRWG | A11515ENC160118 |